

This article was downloaded by:

On: 24 January 2011

Access details: *Access Details: Free Access*

Publisher *Taylor & Francis*

Informa Ltd Registered in England and Wales Registered Number: 1072954 Registered office: Mortimer House, 37-41 Mortimer Street, London W1T 3JH, UK



Journal of Liquid Chromatography & Related Technologies

Publication details, including instructions for authors and subscription information:

<http://www.informaworld.com/smpp/title~content=t713597273>

Development of a High Performance Ion Chromatographic (HPIC) Method for the Determination of Sodium Metabisulfite in Parenteral Formulations

D. E. Herbranson^a; M. S. Eliason^a; N. N. Karnatz^a

^a Du Pont Critical Care, Waukegan, Illinois

To cite this Article Herbranson, D. E. , Eliason, M. S. and Karnatz, N. N.(1987) 'Development of a High Performance Ion Chromatographic (HPIC) Method for the Determination of Sodium Metabisulfite in Parenteral Formulations', *Journal of Liquid Chromatography & Related Technologies*, 10: 15, 3441 – 3450

To link to this Article: DOI: 10.1080/01483918708081882

URL: <http://dx.doi.org/10.1080/01483918708081882>

PLEASE SCROLL DOWN FOR ARTICLE

Full terms and conditions of use: <http://www.informaworld.com/terms-and-conditions-of-access.pdf>

This article may be used for research, teaching and private study purposes. Any substantial or systematic reproduction, re-distribution, re-selling, loan or sub-licensing, systematic supply or distribution in any form to anyone is expressly forbidden.

The publisher does not give any warranty express or implied or make any representation that the contents will be complete or accurate or up to date. The accuracy of any instructions, formulae and drug doses should be independently verified with primary sources. The publisher shall not be liable for any loss, actions, claims, proceedings, demand or costs or damages whatsoever or howsoever caused arising directly or indirectly in connection with or arising out of the use of this material.

DEVELOPMENT OF A HIGH PERFORMANCE ION CHROMATOGRAPHIC (HPIC) METHOD FOR THE DETERMINATION OF SODIUM METABISULFITE IN PARENTERAL FORMULATIONS

D. E. Herbranson, M. S. Eliason, and N. N. Karnatz

*Du Pont Critical Care
1600 Waukegan Road
Waukegan, Illinois 60085*

ABSTRACT

A high performance ion chromatographic (HPIC) method for the determination of sodium metabisulfite (a pharmaceutical antioxidant) in injectable formulations is described. The method is selective for both the sulfite and sulfate ions with a minimum of sample preparation.

INTRODUCTION

Sodium metabisulfite ($\text{Na}_2\text{S}_2\text{O}_5$) is used in pharmaceutical injectables as an antioxidant/stabilizer. In the solid form, sodium metabisulfite coexists with sodium bisulfite (NaHSO_3) (~66% NaHSO_3), but when in an aqueous solution both are readily converted to the SO_3^{2-} ion ($\text{pK}_a=7.2$). The most common method for the quantitation of sulfite, as SO_2 , is a classical iodimetric titration where a known amount of iodine is added to the solution, oxidizing the sulfite to sulfate and the excess iodine titrated with sodium thiosulfate. In the case of some pharmaceutical injectable formulations, this method is not viable. Due to

various chemical interactions that are possible in the classic titrimetric method, another method for sulfite determination was developed.

High Performance Ion Chromatography (HPIC) is a separation technique similar to HPLC and is used to separate charged species based upon an ion exchange mechanism and suppressed conductivity detection. Since its introduction in the mid-1970's, this technique has rapidly become commonplace in several industries, particularly the pharmaceutical sector.

Sulfite and sulfate ions are divalent anions in solution at high pH (>8) with high conductivity and are good candidates for analysis by HPIC. Because the oxidation of the sulfite ion to sulfate is relatively rapid in an aqueous solution, direct measurement of the ion by HPIC has been found to be suitable in each of these cases. It has been documented that sulfite solutions prepared in an aqueous solution of formaldehyde stabilize the sulfite such that quantitative detection may take place without sulfate degradation.^(1,2) Using the described technique, the sulfite/sulfate ion content can be monitored in pharmaceutical solutions.

EXPERIMENTAL

Materials

Sodium bisulfite, sodium sulfate anhydrous, sodium carbonate anhydrous, sodium bicarbonate and formaldehyde solution (~37%), all AR grade were used as received. Sulfuric acid, ACS grade was also used as received. Freshly prepared purified water (Millipore Corp., Bedford, MA) was used throughout the procedure.

Instrumentation

All chromatography was performed on a Dionex (Sunnyvale, CA) 2010i eluent delivery/conductivity detector system. A Gilson Minipuls 2 pump (Middleton, WI) was employed for suppressor regenerant delivery. A Modified Perkin-Elmer (Norwalk, CT) LC-420 autosampler equipped with a 50 μ L teflon tube sample loop was used for sample introduction. A Hewlett-Packard (Avondale, PA) Model 3357 lab data system was used for all peak area calculations. Separations were made with Dionex HPIC-AG4 guard and HPIC-AS4 separator columns. Background noise suppression was performed using a Dionex anion fiber suppressor (AFS).

Eluent/Regenerant

The eluent consisted of 0.0035 M Na_2CO_3 which was pumped at a rate of 1.0 mL/minute. The suppressor regenerant was 0.05 M H_2SO_4 which was pumped at a rate of 2 mL/minute. Both the eluent and regenerant were filtered (by vacuum) through a 0.45 μ m filter prior to use.

Standard/Sample Diluent

The diluent used for all standard and sample preparations was prepared by transferring 0.5 mL of the formaldehyde solution (~37%) to 2.0 liters of water. The final concentration of HCHO in solution was ~0.01%.

Standard Curves

A stock standard sodium bisulfite solution was prepared by accurately weighing 1.0 g of sodium bisulfite, transferring this to a 100 mL volumetric

flask and diluting to volume with the Standard/Sample Diluent (10 mg/mL). A stock standard sodium sulfate solution was prepared separately in a similar manner. Standard curve concentrations of 100, 80, 60, 40, 20 and 0 $\mu\text{g/mL}$ sodium bisulfite and sodium sulfate were prepared separately by diluting appropriate volumes of the stock standards with the Standard/Sample Diluent. All standards were made fresh on the day of analysis to keep the sulfite to sulfate oxidation to a minimum.

Sample Preparation

All of the pharmaceutical samples tested contained the same theoretical concentration of sodium bisulfite of 1.0 mg/mL. One dilution, 4 mL of sample in 50 mL (volumetric flask) of the Standard/Sample Diluent, yielded an 80 $\mu\text{g/mL}$ theoretical sodium bisulfite concentration.

RESULTS & DISCUSSION

HPIC was used as the separation mode because of the nature of the ions involved. Both the sulfite and sulfate ions occur as divalent anions in the solvent system as described previously. The use of this high performance ion exchange system coupled with a conductivity detector offers a fast and easy quantitation of both sulfite (SO_3^{2-}) and sulfate (SO_4^{2-}), its oxidation product, in the injectable formulation.

The initial problem encountered was the ability to stabilize the SO_3^{2-} content in the sample during dilution prior to injection. It has been reported that addition of formaldehyde stabilizes the SO_3^{2-} in solutions by forming a detectable complex.⁽¹⁾ Through a series of experiments, it was observed that a dilute (0.01% v/v) solution of HCHO can be used as a diluent for standard and

sample preparation prior to injection. By using this HCHO diluent for all standard/sample dilutions no observable degradation from SO_3^{2-} to SO_4^{2-} was noted for two days. Sodium carbonate (Na_2CO_3) and sodium bicarbonate (NaHCO_3) eluents were examined separately and mixed together for use as anionic eluents for the HPIC system. In terms of relative strength, Na_2CO_3 is stronger than NaHCO_3 as an eluent since the eluting ion for bicarbonate is monovalent whereas carbonate is divalent. Using only 0.0025 M Na_2CO_3 as the eluent, both the SO_3^{2-} and SO_4^{2-} peaks were easily resolved with both peaks eluting in less than 10 minutes. By increasing the molarity of the Na_2CO_3 eluent in small increments, the retention times for both peaks decreased dramatically. Also, the peak shape improved for both peaks (Figure 1).

To examine the effect of NaHCO_3 on the chromatography, the Na_2CO_3 was held constant at 0.0035 M. The NaHCO_3 molarity was increased in small increments and an unexpected phenomenon occurred. The SO_4^{2-} retention time slowly decreased and became sharper. The retention time of SO_3^{2-} did not noticeably change but the peak began to broaden and its height decreased as the NaHCO_3 level increased (Figure 2). This phenomenon, though unexplainable at this time, was regarded as unsuitable for a routine method. Therefore, all use of NaHCO_3 as part of the eluent was abandoned.

The Dionex AS4 column was chosen as the separator column over the only other column available for this separation, the AS4A, because it provided better peak shape and resolution for both SO_3^{2-} and SO_4^{2-} peaks. A guard column utilizing the same packing was used to protect the system from potential contaminants in the samples.

The final chromatogram of the pharmaceutical injectable shows only three eluting peaks of interest (Figure 3). The SO_3^{2-} and SO_4^{2-} peaks are resolved from each other as well as from other extraneous peaks.

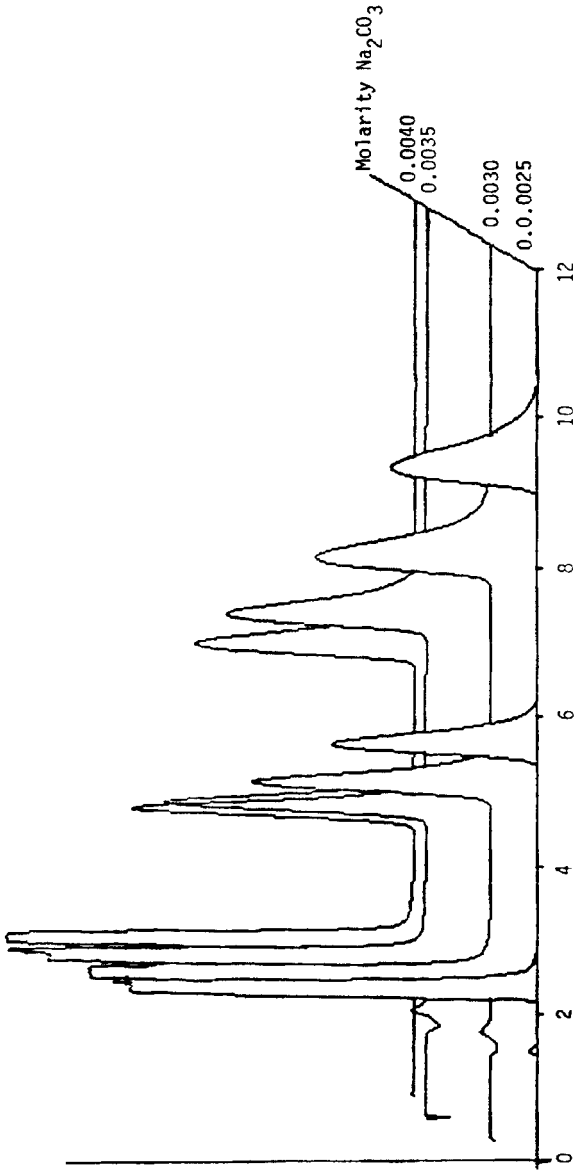

Figure 1

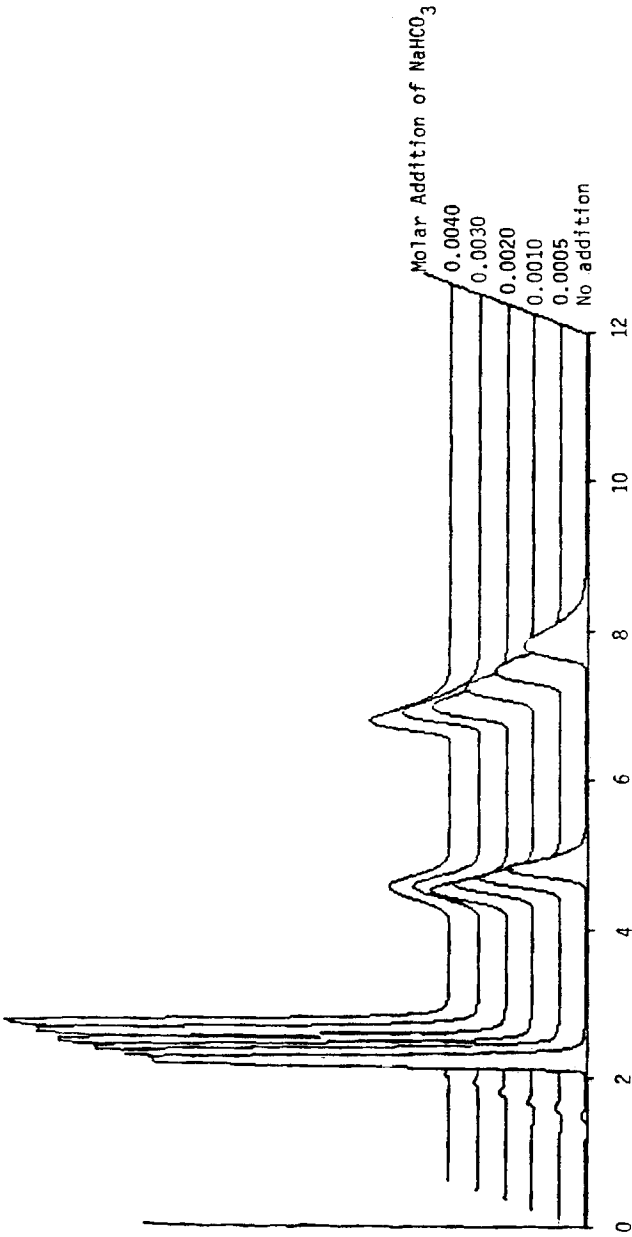

Figure 2

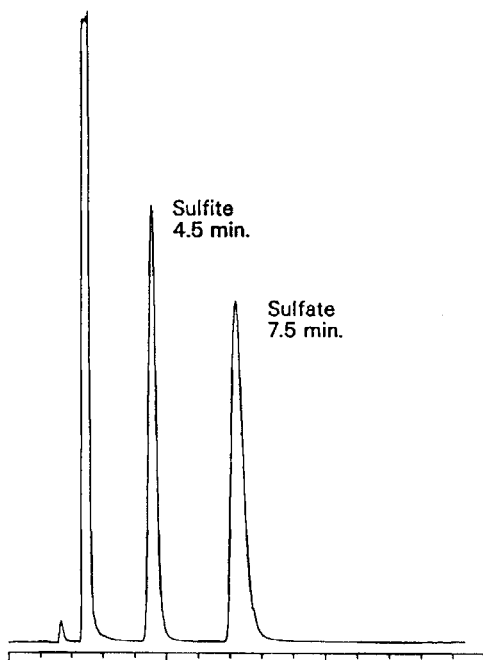

Figure 3 Analysis of sulfite and sulfate in a parenteral formulation.

Analysis of Pharmaceutical Injectable Lots

Peak area measurements of both the SO_3^{2-} and SO_4^{2-} peaks were performed automatically by the data system. The NaHSO_3 and Na_2SO_4 standards injected were used to construct separate least square calibration lines for the SO_3^{2-} and SO_4^{2-} determinations. A single analyst examined seven lots of the injection formulation located in our stability system. Since all of the injectable lots contained the same 1.0 mg/mL theoretical concentration of NaHSO_3 , the standard curve concentrations were set up to bracket the diluted sample concentration of NaHSO_3 and sulfate degradation. Individual ampuls were analyzed in order to determine the variance in the method since it is possible

Table I

Lot	Number Tested	X NaHSO ₃ (% of Labeled Amount)	s (Standard Deviation)
A	2	74.5	2.47
B	4	75.5	7.01
C	7	61.8	11.28
D	7	57.3	13.77
E	7	54.4	17.04
F	7	38.4	11.29

Table II

Lot	Number Tested	Total NaHSO ₃ Measured in Lot *	% of Theoretical Initial Concentration
A	7	1.007 mg/mL	100.75%
B	7	1.0669 mg/mL	106.69%
C	7	1.0063 mg/mL	100.63%
D	7	0.9483 mg/mL	94.37%

* includes correction of sulfate degradation data to sodium bisulfite.

that with a moderately unstable ion such as SO_3^{2-} , no two ampuls will have identical sulfite levels. In all analyses, both the NaHSO_3 and Na_2SO_4 standard curves produced correlation coefficients of >0.99 . Although the NaHSO_3 curves produced a large negative intercept, this value accounted for less than 2% of the average theoretical concentrations.

Table I shows the variance between individual ampuls of lots tested for NaHSO_3 content. Although the variation in the individual lots is large, their deviation can be expected due to the instability of the SO_3^{2-} ion in solution and to the variation of their exposure to air. When the SO_4^{2-} content is corrected to NaHSO_3 to reflect the oxidation of SO_3^{2-} , the values for total NaHSO_3 content reflects the theoretical value very closely (Table II). When this summation of NaHSO_3 values occur, the precision between samples is actually quite good (CV $<6\%$ where $n=7$). Due to the variance of actual SO_3^{2-} content between ampuls, a minimum of three ampuls should be analyzed to determine a single lots NaHSO_3 content.

CONCLUSION

A method for determining sodium bisulfite in pharmaceutical injectable formulations has been developed. This method can be used to measure both sulfate and sulfite content in the formulated product. The method is easy to perform, requiring only dilute aqueous solutions of buffers, acids, and samples. This method yields an accurate determination of the sodium bisulfite content in an individual ampul or vial of an injectable formulation in less than 10 minutes per sample.

REFERENCES

1. M.J. McCormick and L.M. Dixon, J. Chrom. 322, p. 478-483 (1985).
2. F.C. Smith, Jr. and R.C. Chang, "The Practice of Ion Chromatography," John Wiley and Sons, New York, NY, 1983.